

# Two Probes, Two Hierarchy Effects: Agreement and Incorporation Restrictions in Southern Tiwa

Joe Class

## 1. Introduction

Southern Tiwa (Kiowa-Tanoan) exhibits two PCC-like hierarchy effects, both of which interact with the language's productive system of noun incorporation (Rosen 1990, Heck & Richards 2010). The first hierarchy effect, which is similar to the weak PCC, bans a 3rd person agent (AG) from c-commanding any lower argument that is 1st person, 2nd person or non-incorporated. The second hierarchy effect, which resembles the strong PCC, bans an applied argument of *any person* (APP) from c-commanding a 1st person, 2nd person or non-incorporated internal argument (IA).<sup>1</sup> Adopting terms from the previous literature on Southern Tiwa, where agents and applied arguments are respectively referred to as “ergatives” and “datives,” I call these hierarchy effects the *Ergative Restriction* and the *Dative Restriction*.<sup>2</sup>

### (1) Hierarchy Effects in Southern Tiwa

Ergative Restriction	Dative Restriction
*3 <sub>AG</sub> > 1/2/non-incorp	*1/2/3 <sub>APP</sub> > 1/2/non-incorp <sub>IA</sub>

In this paper, I propose that this complex pattern results from a specific interplay between the nominal licensing requirements of DPs and the featural specifications of two individual  $\varphi$ -probes. Building off of Heck and Richards' (2010) previous analysis of the pattern, I propose that all the arguments involved in each restriction carry a *person* [ $\pi$ ] feature, which must be *licensed* by participating in Agree (Béjar & Rezac 2009). I then propose that Southern Tiwa has two distinct person probes that differ in the specific features that trigger Agree. In the configurations in (1), these probes are *unable* to license every argument's [ $\pi$ ] feature, leading to ungrammaticality.

An interesting feature of this analysis is that licensing failures arise for two distinct reasons within the same language. The Dative Restriction is essentially an intervention effect, in that a higher argument blocks a probe from licensing a [ $\pi$ ] feature on a lower argument. The Ergative Restriction, on the other hand, results from a mismatch between the features on an argument that require licensing and the features that trigger Agree.

In the following section, I provide further background on Southern Tiwa, specifically focusing on the two hierarchy effects in (1). All examples come from Allen et al. (1984) and Rosen (1990).

## 2. Two Hierarchy Effects in Southern Tiwa

Southern Tiwa is characterized by rich agreement morphology. For any clause, a single agreement portmanteau can encode the person, number and “noun class” features – labelled ‘A’ ‘B’ or ‘C’ – of up to three arguments (Allen et al. 1984, Rosen 1990).

- (2) **ka-musa-wia-ban**  
1SG>2SG>A(3SG)-cat-give-PAST  
'I gave the cat to you'

---

\* Joe Class, University of California Los Angeles, joe.class22@ucla.edu. A special thanks goes to Stefan Keine and Ethan Poole for their helpful comments and criticism.

<sup>1</sup> I use the term “applied argument” to refer to goals in ditransitives, as well as targets of motion for verbs such as *hliaw*- ‘come down.’

<sup>2</sup> I make no claims about the actual case values of these arguments.

“Noun class” agreement in Southern Tiwa has been successfully decomposed into number agreement along the lines of a *number inverse system* (Noyer 1992). I therefore do not include it in the rest of my glosses, and just indicate the basic person and number agreement features.

### 2.1. Noun Incorporation and its Restrictions

Southern Tiwa exhibits a productive process of noun incorporation, which is restricted by factors such as animacy and argument type. First, only internal arguments can incorporate. External arguments such as agents and applied arguments such as goals never incorporate (Allen et al. 1984, Rosen 1990).

#### (3) Agents and Applied Arguments do not Incorporate

- |  |   |
|--|---|
| <p>a. Non-incorporated Agent</p> <p>hliawrade Ø-k’ar-hi yede<br/> lady 3SG&gt;3SG-eat-FUT that<br/> ‘The lady will eat that’</p>         | <p>c. Non-incorporated Applied Argument</p> <p>ta-u’u-wia-ban hliawrade<br/> 1SG&gt;3SG&gt;3SG-baby-give-PAST woman<br/> ‘I gave the baby to the woman’</p>       |
| <p>b. *<b>Incorporated Agent</b></p> <p>*Ø-hliawra-k’ar-hi yede<br/> 3SG&gt;3SG-lady-eat-FUT that<br/> Int: ‘The lady will eat that’</p> | <p>d. *<b>Incorporated Applied Argument</b></p> <p>*ta-hliaw-u’u-wia-ban<br/> 1SG&gt;3SG&gt;3SG-woman-baby-give-PAST<br/> Int: ‘I gave the baby to the woman’</p> |

The obligatoriness of incorporation depends on animacy. Inanimate internal arguments *must* incorporate. Animate internal arguments which are human or “highly specific” need not incorporate, so long as non-incorporation does not violate the Ergative or the Dative Restriction (Allen et al. 1984, Rosen 1990).

#### (4) Incorporation and Animacy

- |  |  |
|--|--|
| <p>a. Incorporated Inanimate</p> <p>Yede ti-shut-pe-ban<br/> that 1SG&gt;3SG-shirt-make-PAST<br/> ‘I made that shirt’</p>                          | <p>c. Incorporated Animate</p> <p>Ti-seuan-mū-ban<br/> 1SG&gt;3SG-man-see-PAST<br/> ‘I saw the/a man’</p>        |
| <p>b. *<b>Non-incorporated Inanimate</b></p> <p>*Yede <b>shut</b> ti-pe-ban<br/> that shirt 1SG&gt;3SG-make-PAST<br/> Int: ‘I made that shirt’</p> | <p>d. Non-incorporated Animate</p> <p>Seuanide ti-mū-ban<br/> Man 1SG&gt;3SG-see-PAST<br/> ‘I saw the/a man’</p> |

### 2.2. Two Configurations, Two Hierarchy Effects

As stated earlier, Southern Tiwa shows two hierarchy effects that resemble the weak and the strong PCC, but also extend to the incorporated/non-incorporated status of the lower argument. The Ergative Restriction bans configurations where a 3rd person agent c-commands a lower argument that is 1st person, 2nd person or non-incorporated (Rosen 1990, Heck & Richards 2010). This is best seen in the basic transitive configurations below. Note that “xxx” indicates that no agreement portmanteau is available.

#### (5) Ergative Restriction (\*3<sub>AG</sub> > 1/2/non-incorporated)

- |   |  |
|---|--|
| <p>a. 1<sub>AG</sub> &gt; incorporated<sub>IA</sub></p> <p>Ti-seuan-mū-ban<br/> 1SG&gt;3SG-man-see-PAST<br/> ‘I saw the/a man’</p>        | <p>d. 3<sub>AG</sub> &gt; incorporated<sub>IA</sub></p> <p>Ø-seuan-mū-ban<br/> 3SG&gt;3SG-man-see-PAST<br/> ‘He saw the/a man’</p>               |
| <p>b. 1<sub>AG</sub> &gt; non-incorporated<sub>IA</sub></p> <p>Seuanide ti-mū-ban<br/> Man 1SG&gt;3SG-see-PAST<br/> ‘I saw the/a man’</p> | <p>e. *3<sub>AG</sub> &gt; non-incorporated<sub>IA</sub></p> <p>*Seuanide Ø-mū-ban<br/> Man 3SG&gt;3SG-see-PAST<br/> Int: ‘He saw the/a man’</p> |

- c.  $1_{AG} > 2_{IA}$   
 I-mũ-ban  
 1SG>2SG-see-PAST  
 ‘I saw you’
- f.  $*3_{AG} > 2_{IA}$   
 \*Uide xxx-mũ-ban  
 Child 3SG>2SG-see-PST  
 Int: ‘The child saw you’

Whereas a 1st person agent can c-command basically any type of lower argument (5a-c), a 3rd person agent is ungrammatical in the context of a non-incorporated internal argument (5e), as well as a 2nd person internal argument (5f).

The Dative Restriction is more strict than the Ergative Restriction, banning an applied argument of *any person* from c-commanding a 1st person, 2nd person or non-incorporated internal argument (Rosen 1990, Heck & Richards 2010). This is best seen in configurations with directional verbs such as *hliaw* ‘come down,’ or *wan-* ‘come,’ where an applied argument indicating the target of motion c-commands a lower argument. When the applied argument is 1st person, the only grammatical configuration is one where the lower argument is 3rd person and incorporated (6a).

(6) Dative Restriction ( $*1/2/3_{APP} > 1/2/\text{non-incorporated}_{IA}$ )

- a.  $1_{APP} > \text{incorporated}_{IA}$   
 Im-musa-hliaw-ban  
 1SG>3PL-cats-come.down-PAST  
 ‘The cats came down to me’
- c.  $*1_{APP} > 2_{IA}$   
 \*xxx-wan-ban  
 1SG>2SG-come-PAST  
 Int: ‘You came to me’
- b.  $*1_{APP} > \text{non-incorporated}_{IA}$   
 \*Musan im-hliaw-ban  
 cats 1SG>3PL-come.down-PAST  
 Int: ‘The cats came down to me’

The Ergative and Dative Restrictions interact with each other in ditransitive constructions, where an agent c-commands an applied goal argument, which in turn c-commands an internal theme argument. Because the Dative Restriction bans configurations where an applied argument c-commands anything that is not an incorporated 3rd person argument, the internal theme argument in ditransitives *must undergo incorporation*. As a result, (7a) below is ungrammatical. Because applied arguments never undergo incorporation themselves, the agent in ditransitives has to be *1st or 2nd person*, as a 3rd person agent would violate the Ergative Restriction ( $*3_{AG} > 1/2/\text{non-incorporated}$ ). This rules out (7b).

(7) Restrictions on Ditransitives

- a.  $1_{AG} > 2_{APP} > * \text{non-incorp}_{IA}$   
 \*’U’ude ka-wia-ban  
 baby 1SG>2SG>3SG-give-PAST  
 Int: ‘I gave the baby to you’
- b.  $*3_{AG} > 3_{APP} > 3_{IA}$   
 \*xxx-wia-ban  
 3SG>3SG>3PL-give-PAST  
 Int: ‘He gave them to him/her’

With the basic pattern established, I now review the essentials of Heck and Richards’ (2010) analysis. While I ultimately adopt their characterization of the Ergative and Dative Restrictions from a featural standpoint, I argue that these restrictions arise for entirely different reasons.

### 3. Heck and Richards 2010: Restrictions on DPs

Heck and Richards (2010) analyze both the Ergative the Dative Restriction as constraints on the distribution of *DPs*, something that follows from their assumptions about the distribution of person  $[\pi]$  features. Building off of work from Adger and Harbour (2007) and Harbour (2007), they assume that agents and applied arguments *always* bear a  $[\pi]$  feature. The same goes for all 1st and 2nd person arguments, regardless of their structural position. The only arguments that can vary in whether they have a  $[\pi]$  feature are therefore 3rd person internal arguments. Here, Heck and Richards assume that *only* animate, non-incorporating arguments bear a  $[\pi]$  feature.

Adopting a proposal from Richards (2008), Heck and Richards assume further that  $[\pi]$  features are instantiated on a D head. As a result, all arguments with a  $[\pi]$  feature are DPs, whereas arguments without a  $[\pi]$  feature are bare NPs.<sup>3</sup> The DP/NP distinction also underlies the incorporation/non-incorporation distinction. DPs never undergo incorporation, whereas NPs undergo incorporation obligatorily.<sup>4</sup> Under this system, the Ergative and the Dative Restriction can therefore be reformulated as the following.

(8) Hierarchy Effects in Southern Tiwa (Reformulated)

Ergative Restriction	Dative Restriction
$*3_{AG} > 1/2/\text{non-incorp} = *3DP_{AG} > DP$	$*1/2/3_{APP} > 1/2/\text{non-incorp}_{IA} = *DP_{APP} > DP_{IA}$

The Ergative Restriction bans a 3rd person agent DP from c-commanding any lower DP, whereas the Dative Restriction bans any applied argument DP from c-commanding an internal argument DP.

Heck and Richards ultimately propose that *failure to value a probe* leads to ungrammaticality in the configurations above. Abstracting away from the minor details, a probe on T or v with an unvalued “noun class”  $[CLASS]$  feature is unable to find a valued noun class feature on any argument, leading to a crash at the interfaces. This proposal is undesirable for several reasons. First, it is now widely assumed that failure to value a probe does not crash the derivation (Preminger 2014). Second, the idea that “noun class” in Southern Tiwa is its own primitive feature is dubious, given that it has been previously decomposed into number (Noyer 1992).

Nonetheless, Heck and Richard’s reformulation of both the Ergative and the Dative Restriction in (8) serves as a promising starting point for any alternative analyses. As such, I *fully* adopt this reformulation, specifically the crucial assumption that all the arguments involved in each restriction carry a  $[\pi]$  feature. In the next section I turn towards my own analysis.

#### 4. Analysis: Nominal Licensing meets Two Distinct Probes

Many analyses of the PCC and related hierarchy effects propose that they result from *failures in nominal licensing* (Anagnostopoulou 2003, Béjar & Rezac 2003, 2009, Preminger 2011, 2014). Certain features on a DP must be licensed by participating in an Agree relationship, and failure to do so results in ungrammaticality. The specific configurations banned by the PCC or other hierarchy effects are therefore those in which a feature that requires licensing is unable to participate in Agree.

The features that are most commonly taken to require licensing are person  $[\pi]$  features – a proposal often referred to as the *Person Licensing Condition* (PLC). Given that both the Ergative and the Dative Restriction exclusively involve DPs with a  $[\pi]$  feature, I adopt the Béjar and Rezac’s (2009) version of PLC for Southern Tiwa, specifically proposing that all instances of the “basic” person feature  $[\pi]$  must be licensed, as summarized below.

(9) Person Licensing Condition (Southern Tiwa)

A  $[\pi]$  feature must be licensed by participating in Agree

For person features themselves, I follow Harley and Ritter (2002) and Béjar (2003) in assuming that they are organized into feature geometries that reflect certain entailment relationships. I specifically assume that the “basic” feature  $[\pi]$  serves as the root of the person feature geometry, such that all 1st person, 2nd person and 3rd person DPs bear  $[\pi]$ . 1st and 2nd person DPs have an additional *participant* feature  $[PART]$ , which entails the presence of a  $[\pi]$  feature. This gives rise to the geometry  $[\pi - PART]$ . 1st and 2nd person DPs may be distinguished further from one another via an additional feature, but that is irrelevant for our purposes.

<sup>3</sup> If we adopt Harbour’s (2007) analysis of number inverse systems, it may be better to minimally analyze bare NP arguments as NumPs.

<sup>4</sup> Heck and Richards (2010) derive this distinction using Roberts’ (2010) analysis of noun incorporation. On the other hand, I remain completely neutral as to what drives noun incorporation. It could arguably be head movement (Baker 1985). Alternatively, NPs/NumPs may be too “small” syntactically to form independent prosodic words (Compton & Pittman 2010).

Turning towards agreement, I assume that the operation Agree is driven by unvalued features on a head (probes), which search their c-command domain for a valued feature, in turn copying that value back to the head. Following Preminger (2014) and Deal (2015, 2022), I assume that probes can be relativized to search for *specific individual features* within a larger  $\varphi$ -feature geometry, even if those features do not form the root of the geometry. For the sake of concreteness, I adopt Deal’s (2015, 2022) *Interaction/Satisfaction* model of Agree. An individual probe can have both an *interaction* condition – [INT:  $\alpha$ ] – which specifies the feature that triggers copying, and a *satisfaction* condition – [SAT:  $\beta$ ] – which specifies the feature that halts the probe’s search. For licensing purposes then, a feature X “participates” in Agree if it is copied to a head by a probe, *or* if a feature Y that entails X is copied (Béjar and Rezac 2009). Finally, I follow Preminger (2014) in assuming that failure to value a probe does not result in ungrammaticality.

With this in place, I propose that the Ergative and the Dative Restriction result from two distinct probes that have different *interaction conditions*. The first probe, which is located on v, has the root person feature [  $\pi$  ] as both its interaction and satisfaction condition ([INT:  $\pi$ , SAT:  $\pi$ ]). The second probe, which is located on an inflectional head Infl that c-commands v, has the more specific *participant* feature [PART] as its interaction and satisfaction condition ([INT: PART, SAT: PART]). Under the assumption that agents are merged in the specifier of v, and applied arguments are merged in the specifier of an applicative head Appl, this gives us the following clausal architecture.

(10) Clausal Architecture

[InflP Infl<sub>[INT: PART, SAT: PART]</sub> [VP DP<sub>AG</sub> V<sub>[INT:  $\pi$ , SAT:  $\pi$ ]</sub> [AppIP DP<sub>APP</sub> Appl [VP V DP<sub>IA</sub>]]]]

4.1. Deriving the Ergative Restriction (\*3DP<sub>AG</sub> > DP)

To see how this system derives the Ergative Restriction (\*3DP<sub>AG</sub> > DP), it is first worth going through two grammatical derivations for basic transitive sentences. First, consider a configuration where a [PART]-bearing 1st person agent c-commands a DP internal argument (recalling that all 1st person, 2nd person and non-incorporating internal arguments are DPs with a [  $\pi$  ] feature). When v merges, the [INT:  $\pi$ , SAT:  $\pi$ ] probe searches its c-command domain and agrees with the [  $\pi$  ] feature on the internal argument, thereby licensing the [  $\pi$  ] feature. This is shown in (11a). Next, the 1st person agent and Infl merge. The [INT: PART, SAT: PART] probe on Infl searches its c-command domain and agrees with the [PART] feature on the 1st person agent, which in turn licenses the agent’s [  $\pi$  ] feature, as seen in (11b). All the [  $\pi$  ] features are therefore successfully licensed, and the derivation converges.<sup>56</sup>

(11) 1DP<sub>AG</sub> > DP<sub>IA</sub>

a. Agreement with Internal Argument

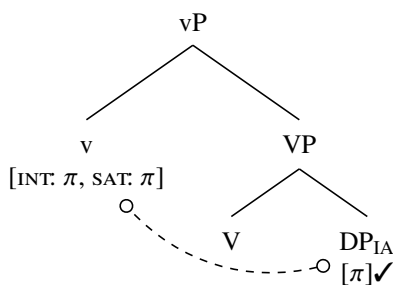

b. Agreement with Agent

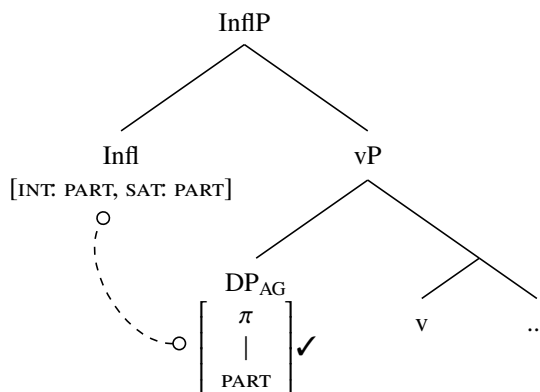

<sup>5</sup> To capture number agreement, I propose that v also carries an *insatiable* probe which has number [#] as an interaction condition, but no satisfaction condition ([INT: #, SAT:  $\emptyset$ ]). Upon merger of v, this probe copies the number features from any DPs in its c-command domain, but does not stop its search. Following Béjar and Rezac (2009), I assume that it *reprojects* in the next cycle, giving it the ability to also copy number features from the agent DP.

<sup>6</sup> Although two heads agree in the derivation in (11), agreement is spelled out in a single portmanteau, as seen in (2). To capture this, I propose that the features of Infl and v are spelled-out in a single span (Svenonius 2016).

Next, consider a configuration where a 3rd person agent c-commands an NP internal argument. When *v* merges in (12a), the [INT:  $\pi$ , SAT:  $\pi$ ] probe fails to find any [ $\pi$ ] features in its c-command domain, since NP arguments completely lack [ $\pi$ ]. Again following Béjar and Rezac (2009), I assume that the probe then *reprojects*, giving it the ability to target any potential arguments merged in the next cycle. As a result, [INT:  $\pi$ , SAT:  $\pi$ ] agrees with the [ $\pi$ ]-bearing 3rd person agent once it is merged in [spec, *v*]. This is shown in (12b). Again, all the [ $\pi$ ] features are successfully licensed.<sup>7</sup>

(12) 3DP<sub>AG</sub> > NP<sub>IA</sub>

a. No Agreement in First Cycle

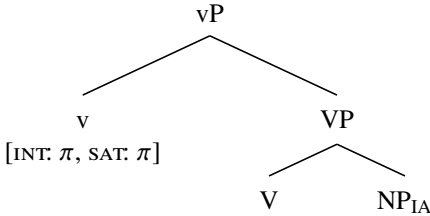

b. Agreement with Agent in Next Cycle

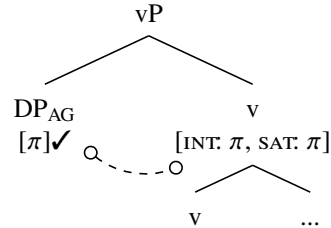

Finally, we turn to an ungrammatical derivation where a 3rd person agent c-commands a *DP* internal argument. In a similar fashion to (11), the [INT:  $\pi$ , SAT:  $\pi$ ] probe on *v* agrees with the *DP* internal argument, licensing its [ $\pi$ ] feature. When the 3rd person agent and Infl merge, however, the [INT: PART, SAT: PART] probe *cannot* agree with the agent. While 3rd person agents have a [ $\pi$ ] feature, they lack [PART], and are not a viable target for the [INT: PART, SAT: PART] probe. This leaves the [ $\pi$ ] feature on the 3rd person agent *unlicensed*, which crashes the derivation.

(13) \*3DP<sub>AG</sub> > DP<sub>IA</sub>

a. Agreement with Internal Argument

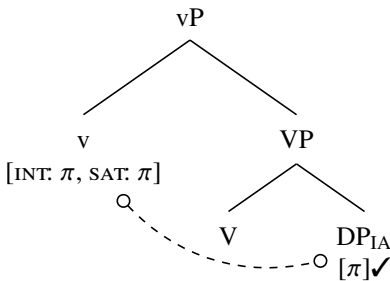

b. No Agreement with 3rd Person Agent

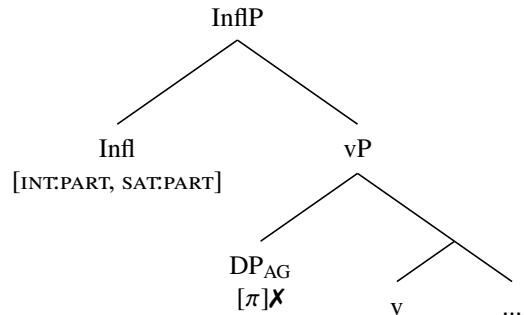

In its essentials then, the Ergative Restriction results from a mismatch between the features on a *DP* that require licensing, and the features that trigger Agree for a certain probe. Although all instances of the root feature [ $\pi$ ] must be licensed by participating in Agree, the probe on Infl only agrees with *DPs* that bear a more specific [PART] feature. When a 3rd person agent, which lacks a [PART] feature, c-commands another *DP*, there is simply no way for the system to license the [ $\pi$ ] feature on the agent.

4.2. Deriving the Dative Restriction (\*DP<sub>APP</sub> > DP<sub>IA</sub>)

In most ways, the Dative Restriction is simpler to capture than the Ergative Restriction. The only grammatical configuration is one in which an applied argument *DP* c-commands an *NP* internal argument. In the derivation for such a configuration, the [INT:  $\pi$ , SAT:  $\pi$ ] probe on *v* agrees with the applied argument, licensing its [ $\pi$ ] feature. Because the *NP* internal argument lacks a [ $\pi$ ] feature, no licensing conflict emerges. This is shown in (14). Consider what happens when an applied argument *DP* c-commands a *DP*

<sup>7</sup> Note that *v* will also agree with a 1st or 2nd person agent in a 1/2DP<sub>AG</sub> > NP<sub>IA</sub> configuration. I remain noncommittal as to whether [INT: PART, SAT: PART] on Infl also agrees with the agent in these derivations.

internal argument, however. Again, the  $[\text{INT: } \pi, \text{SAT: } \pi]$  probe on  $v$  agrees with the applied argument. This both licenses the argument's  $[\pi]$  feature and halts the probe's search. As a result, the  $[\pi]$  feature on the internal argument remains unlicensed, leading to ungrammaticality (15).

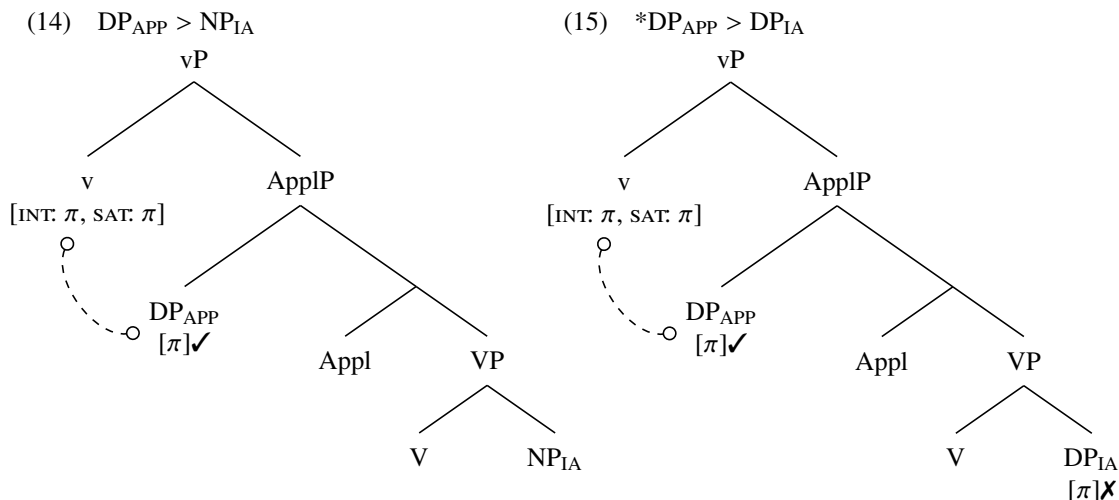

In this sense, the Dative Restriction is reduced to an intervention effect. Whenever the  $[\text{INT: } \pi, \text{SAT: } \pi]$  probe on  $v$   $c$ -commands two DPs, the higher DP prevents it from licensing the  $[\pi]$  feature on the lower DP. This straightforwardly derives the Dative Restriction when the internal argument is a *3rd person DP*. Because the higher probe on Infl has  $[\text{PART}]$  as an interaction condition, it is also unable to agree with a 3rd person internal argument. But consider a case in which a 3rd person applied argument  $c$ -commands a 1st or 2nd person internal argument. Without any further assumptions, the probe on Infl would skip the 3rd person argument and agree with the 1st or 2nd person internal argument, licensing its  $[\pi]$  feature. This would incorrectly predict that 1st or 2nd person internal arguments are grammatical in the context of a 3rd person applied argument – a straightforward violation of the Dative Restriction.

To rule this out, I propose that  $v$  is *always a phase head* in Southern Tiwa. If we assume the strong PIC (Chomsky 2000), the complement of  $v$  undergoes spell-out as soon as the next head (Infl) merges, thereby making anything within the complement of  $v$  inaccessible to further operations. Infl and its probe therefore merge *too late* in the derivation to license any features on the internal argument. As a result, no internal argument DP – regardless of person – is grammatical in the context of an applied argument DP.

(16) Infl Probes too Late

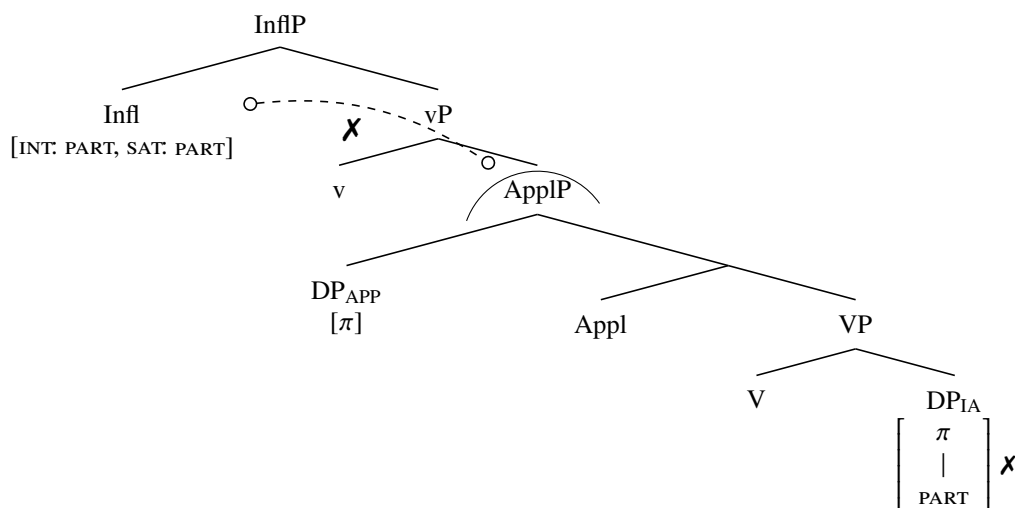

### 4.3. Ditransitives

This model also readily derives the various restrictions seen in ditransitives outlined in section 2. Recall that in a ditransitive, the internal argument cannot be 1st person, 2nd person or non-incorporated, which in our framework translates to a DP. This is captured in the exact same way as the Dative Restriction. The [INT:  $\pi$ , SAT:  $\pi$ ] probe on v always agrees with the structurally higher goal DP, leaving any [ $\pi$ ] feature on the internal argument unlicensed. Moreover, the vP phase will prevent Infl from having an effect. Agents in ditransitives cannot be 3rd person. This is captured in the exact same way as the Ergative Restriction. Because [INT:  $\pi$ , SAT:  $\pi$ ] on v always agrees with the goal, and [INT: PART, SAT: PART] can only agree with 1st or 2nd person agents, there is no way to license the [ $\pi$ ] feature on the 3rd person agent.

## 5. Conclusion

Southern Tiwa exhibits two hierarchy effects that result from nominal licensing failures, albeit nominal licensing fails for different reasons in each case. The Dative Restriction is the result of an intervention effect, in that an applied argument intervenes between a probe and a lower argument, preventing the licensing of a [ $\pi$ ] feature on the lower argument. The Ergative Restriction, on the other hand, is not the result of an intervention effect, but rather a discrepancy between the features on a DP that require licensing and the features specified to trigger Agree for a certain probe.

## References

- Adger, David & Daniel Harbour. 2007. Syntax and syncretisms of the person case constraint. *Syntax* 10(1). 2–37.
- Allen, Barbara, Donna Gardiner & Donald Frantz. 1984. Noun incorporation in Southern Tiwa. *International Journal of American Linguistics* 50. 292–311.
- Anagnostopoulou, Elena. 2003. *The syntax of ditransitives: evidence from clitics*. Berlin: Mouton de Gruyter.
- Baker, Mark. 1985. *Incorporation: a theory of grammatical function changing*. Cambridge: Massachusetts Institute of Technology dissertation.
- Béjar, Susana. 2003. *Phi-syntax: a theory of agreement*. Toronto: University of Toronto dissertation.
- Béjar, Susana & Milan Rezac. 2003. Person licensing and the derivation of PCC effects. In Ana Teresa Pérez-Leroux & Yves Roberge (eds.), *Romance linguistics: theory and acquisition*, 49–62. Amsterdam: John Benjamins.
- Béjar, Susana & Milan Rezac. 2009. Cyclic agree. *Linguistic Inquiry* 40(1). 35–73.
- Chomsky, Noam. 2000. Minimalist inquiries: the framework. In Roger Martin, David Michaels & Juan Uriagereka (eds.), *Step by step: essays on minimalist syntax in honor of Howard Lasnik*, 89–155. Cambridge: MIT Press.
- Compton, Richard & Christine Pittman. 2010. Word-formation by phase in Inuit. *Lingua* 120. 2167–2192.
- Deal, Amy Rose. 2015. Interaction and satisfaction in phi-agreement. In Thuy Bui & Deniz Özyildiz (eds.), *North east linguistic society (NELS) 45*, 179–192. Amherst: GLSA.
- Deal, Amy Rose. 2022. Interaction, satisfaction and the PCC. *Linguistic Inquiry*. 1–56.
- Harbour, Daniel. 2007. *Morphosemantic number: from Kiowa noun classes to UG number features*. Dordrecht: Springer.
- Harley, Heidi & Elizabeth Ritter. 2002. Person and number in pronouns: a feature-geometric analysis. *Language* 78(3). 482–526.
- Heck, Fabian & Marc Richards. 2010. A probe-goal approach to agreement and non-incorporation restrictions in Southern Tiwa. *Natural Language & Linguistic Theory* 28. 681–721.
- Noyer, Rolf. 1992. *Features, positions and affixes in autonomous morphological structure*. Cambridge: Massachusetts Institute of Technology dissertation.
- Preminger, Omer. 2011. Asymmetries between person and number in syntax: a commentary on Baker's SCOPA. *Natural Language & Linguistic Theory* 29. 917–937.
- Preminger, Omer. 2014. *Agreement and its failures*. Cambridge: MIT Press.
- Richards, Marc. 2008. Defective agree, case alternations, and the prominence of person. In Andrej Malchukov & Marc Richards (eds.), *Scales*, 137–161. Leipzig: Universität Leipzig.
- Roberts, Ian. 2010. *Agreement and head movement: clitics, incorporation, and defective goals*. Cambridge: MIT Press.
- Rosen, Carol. 1990. Rethinking Southern Tiwa: The geometry of a triple-agreement language. *Language* 66(4). 669–713.
- Svenonius, Peter. 2016. Spans and words. In Heidi Harley & Daniel Siddiqi (eds.), *Morphological metatheory*, 199–120. Amsterdam: John Benjamins.

# Proceedings of the 41st West Coast Conference on Formal Linguistics

edited by Nikolas Webster, Yağmur Kiper,  
Richard Wang, and Sichen Larry Lyu

Cascadilla Proceedings Project Somerville, MA 2025

## Copyright information

Proceedings of the 41st West Coast Conference on Formal Linguistics  
© 2025 Cascadilla Proceedings Project, Somerville, MA. All rights reserved

ISBN 978-1-57473-483-6 hardback

A copyright notice for each paper is located at the bottom of the first page of the paper.  
Reprints for course packs can be authorized by Cascadilla Proceedings Project.

## Ordering information

Orders for the printed edition are handled by Cascadilla Press.  
To place an order, go to [www.lingref.com](http://www.lingref.com) or contact:

Cascadilla Press, P.O. Box 440355, Somerville, MA 02144, USA  
phone: 1-617-776-2370, fax: 1-617-776-2271, [sales@cascadilla.com](mailto:sales@cascadilla.com)

## Web access and citation information

This entire proceedings can also be viewed on the web at [www.lingref.com](http://www.lingref.com). Each paper has a unique document # which can be added to citations to facilitate access. The document # should not replace the full citation.

This paper can be cited as:

Class, Joe. 2025. Two Probes, Two Hierarchy Effects: Agreement and Incorporation Restrictions in Southern Tiwa. In *Proceedings of the 41st West Coast Conference on Formal Linguistics*, ed. Nikolas Webster et al., 97-104. Somerville, MA: Cascadilla Proceedings Project. [www.lingref.com](http://www.lingref.com), document #3735.